

# ez1084-500 Mic/Line/DI Preamp/EQ (for API 500 series rack)

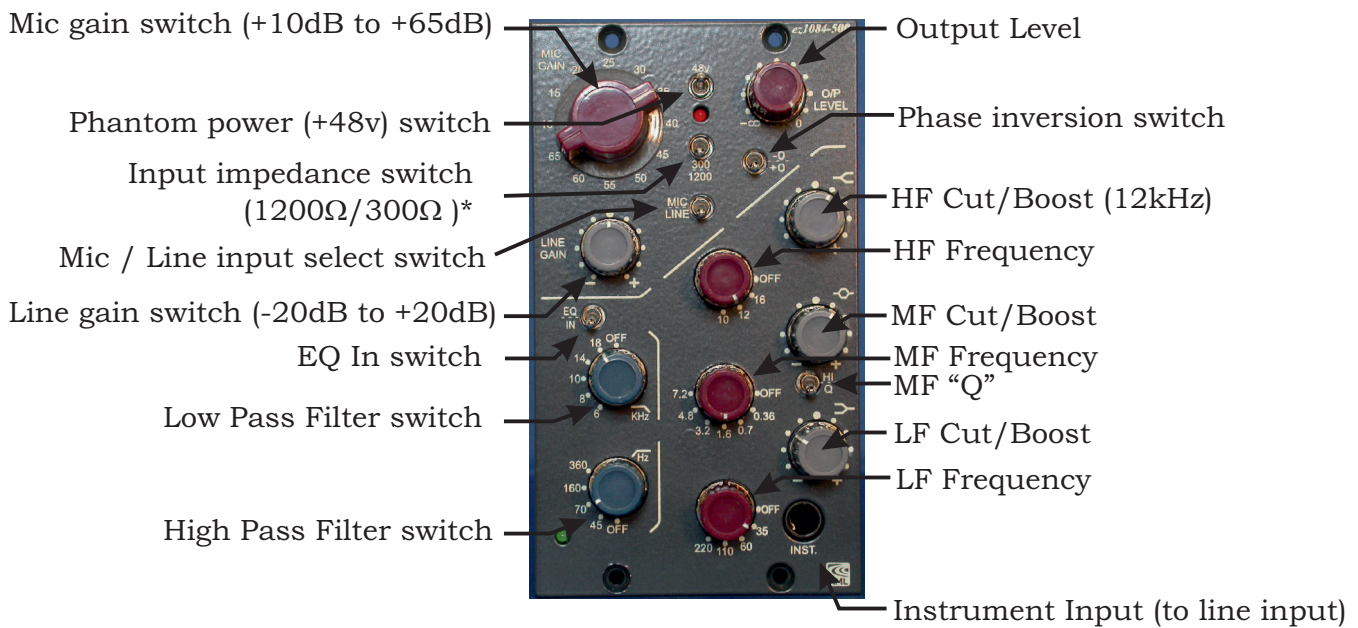

## Installation

The ez1084-500 module is intended for professional application use in the API 500 series VPR racks and Lunchbox.

Installation should be done by a suitably qualified professional.

The units contain no user serviceable components or adjustments. The unit should not be operated without the appropriate racking system as some components become hot during normal operation.

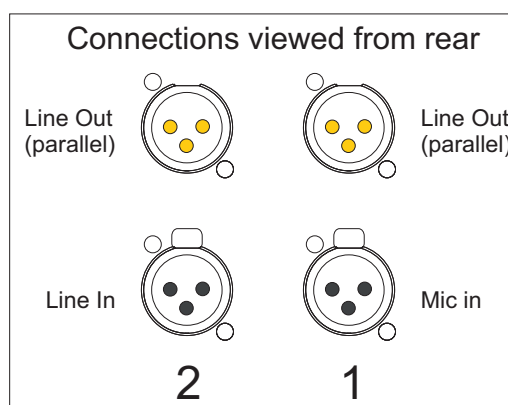

## Use

The ez1084-500 module is designed to mimic analogue tape machine based recording, and as such achieves its “sweet spot” when output levels are in the region +4dBu to +10dBu

\* This is intended for use with 200Ω / 50Ω output impedance microphones, although it may be used as a way of changing the tone of the signal (there will also be a 6dB boost when engaged).